

## Saint-Gobain Isover UK Limited

Saint-Gobain House  
East Leake  
Loughborough  
LE12 6JU



Tel: 01159 698 302

e-mail: [isover.technical@saint-gobain.com](mailto:isover.technical@saint-gobain.com)

website: [www.isover.co.uk](http://www.isover.co.uk)

**Agrément Certificate**

**18/5560**

Product Sheet 2 Issue 3

### ISOVER CAVITY WALL INSULATION

## ISOVER CAVITY WALL SLAB (CWS) 36, ISOVER CAVITY WALL SLAB (CWS) 34 AND ISOVER CAVITY WALL SLAB (CWS) 32 FOR PARTIAL FILL

This Agrément Certificate Product Sheet<sup>(1)</sup> relates to Isover Cavity Wall Slab (CWS) 36, Isover Cavity Wall Slab (CWS) 34 and Isover Cavity Wall Slab (CWS) 32 for partial fill, comprising unfaced glass mineral wool slabs for use as partial fill thermal insulation in new external masonry cavity walls (with a minimum 50 mm residual cavity), in domestic and non-domestic buildings, without height restrictions. Additional requirements apply for buildings above 25 metres. The products are installed during construction.

(1) Hereinafter referred to as 'Certificate'.

#### The assessment includes

##### Product factors:

- compliance with Building Regulations
- compliance with additional regulatory or non-regulatory information where applicable
- evaluation against technical specifications
- assessment criteria and technical investigations
- uses and design considerations

##### Process factors:

- compliance with Scheme requirements
- installation, delivery, handling and storage
- production and quality controls
- maintenance and repair

##### Ongoing contractual Scheme elements†:

- regular assessment of production
- formal 3-yearly review

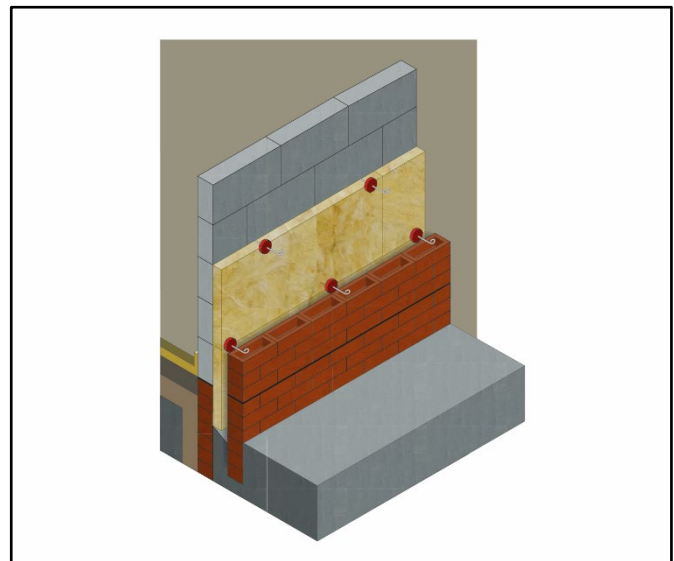

#### KEY FACTORS ASSESSED

- Section 1. Mechanical resistance and stability
- Section 2. Safety in case of fire
- Section 3. Hygiene, health and the environment
- Section 4. Safety and accessibility in use
- Section 5. Protection against noise
- Section 6. Energy economy and heat retention
- Section 7. Sustainable use of natural resources
- Section 8. Durability

The BBA has awarded this Certificate to the company named above for the products described herein. These products have been assessed by the BBA as being fit for their intended use provided they are installed, used and maintained as set out in this Certificate.

On behalf of the British Board of Agrément

Date of Third issue: 17 December 2025

Originally certified on 23 August 2018

Hardy Giesler  
Chief Executive Officer

*This BBA Agrément Certificate is issued under the BBA's Inspection Body accreditation to ISO/IEC 17020. Sections marked with † are not issued under accreditation.*

*The BBA is a UKAS accredited Inspection Body (No. 4345), Certification Body (No. 0113) and Testing Laboratory (No. 0357).*

*Readers MUST check that this is the latest issue of this Agrément Certificate by either referring to the BBA website or contacting the BBA directly. The Certificate should be read in full as it may be misleading to read clauses in isolation.*

*Any photographs are for illustrative purposes only, do not constitute advice and should not be relied upon.*

#### British Board of Agrément

1<sup>st</sup> Floor, Building 3, Hatters Lane  
Croxley Park, Watford  
Herts WD18 8YG

©2025

tel: 01923 665300  
[clientservices@bbacerts.co.uk](mailto:clientservices@bbacerts.co.uk)  
[www.bbacerts.co.uk](http://www.bbacerts.co.uk)

## SUMMARY OF ASSESSMENT AND COMPLIANCE

This section provides a summary of the assessment conclusions; readers should refer to the later sections of this Certificate for information about the assessments carried out.

### Compliance with Regulations

Having assessed the key factors, the opinion of the BBA is that Isover Cavity Wall Slab (CWS) 36, Isover Cavity Wall Slab (CWS 34) and Isover Cavity Wall Slab (CWS) 32 for partial fill, if installed, used and maintained in accordance with this Certificate, can satisfy or contribute to satisfying the relevant requirements of the following Building Regulations:



#### The Building Regulations 2010 (England and Wales) (as amended)

<b>Requirement:</b>	<b>B3(4)</b>	<b>Internal fire spread (structure)</b>
Comment:		The products can contribute to satisfying this Requirement. See section 2 of this Certificate.
<b>Requirement:</b>	<b>B4(1)</b>	<b>External fire spread</b>
Comment:		The products are unrestricted by this Requirement. See section 2 of this Certificate.
<b>Requirement:</b>	<b>C2(a)</b>	<b>Resistance to moisture</b>
Comment:		The products can contribute to satisfying this Requirement. See section 3 of this Certificate.
<b>Requirement:</b>	<b>C2(b)</b>	<b>Resistance to moisture</b>
Comment:		The products can contribute to satisfying this Requirement. See section 9 of this Certificate.
<b>Requirement:</b>	<b>C2(c)</b>	<b>Resistance to moisture</b>
Comment:		The products can contribute to satisfying this Requirement. See section 3 of this Certificate.
<b>Requirement:</b>	<b>L1(a)(i)</b>	<b>Conservation of fuel and power</b>
Comment:		The products can contribute to satisfying this Requirement. See section 6 of this Certificate.
<b>Regulation:</b>	<b>7(1)</b>	<b>Materials and workmanship</b>
Comment:		The products are acceptable. See sections 8 and 9 of this Certificate.
<b>Regulation:</b>	<b>7(2)</b>	<b>Materials and workmanship</b>
Comment:		The products are unrestricted by this Regulation. See section 2 of this Certificate.
<b>Regulation:</b>	<b>25B</b>	<b>Nearly zero-energy requirements for new buildings</b>
<b>Regulation:</b>	<b>26</b>	<b>CO<sub>2</sub> emission rates for new buildings</b>
<b>Regulation:</b>	<b>26A</b>	<b>Fabric energy efficiency rates for new dwellings (applicable to England only)</b>
<b>Regulation:</b>	<b>26A</b>	<b>Primary energy rates for new buildings (applicable to Wales only)</b>
<b>Regulation:</b>	<b>26B</b>	<b>Fabric performance values for new dwellings (applicable to Wales only)</b>
<b>Regulation:</b>	<b>26C</b>	<b>Target primary energy rates for new buildings (applicable to England only)</b>
<b>Regulation:</b>	<b>26C</b>	<b>Energy efficiency rating (applicable to Wales only)</b>
Comment:		The products can contribute to satisfying these Regulations. See section 6 of this Certificate.



## The Building (Scotland) Regulations 2004 (as amended)

<b>Regulation:</b>	<b>8(1)</b>	<b>Fitness and durability of materials and workmanship</b>
Comment:		The products are acceptable. See sections 8 and 9 of this Certificate.
<b>Regulation:</b>	<b>8(3)</b>	<b>Fitness and durability of materials and workmanship</b>
Comment:		The products are unrestricted by this Regulation. See section 2 of this Certificate.
<b>Regulation:</b>	<b>9</b>	<b>Building standards – construction</b>
Standard:	2.4	Cavities
Comment:		The products can contribute to satisfying this Standard, with reference to clauses 2.4.2 <sup>(1)(2)</sup> , 2.4.4 <sup>(1)</sup> and 2.4.6 <sup>(2)</sup> . See section 2 of this Certificate.
Standard:	2.6	Spread to neighbouring buildings
Comment:		The products are unrestricted by this Standard, with reference to clauses 2.6.5 <sup>(1)</sup> and 2.6.6 <sup>(2)</sup> . See section 2 of this Certificate.
Standard:	3.4	Moisture from the ground
Comment:		The products can contribute to satisfying this Standard, with reference to clauses 3.4.1 <sup>(1)(2)</sup> and 3.4.5 <sup>(1)(2)</sup> . See section 3 of this Certificate.
Standard:	3.10	Precipitation
Comment:		The products can contribute to satisfying this Standard, with reference to clauses 3.10.1 <sup>(1)(2)</sup> and 3.10.3 <sup>(1)(2)</sup> . See section 9 of this Certificate.
Standard:	3.15	Condensation
Comment:		The products can contribute to satisfying this Standard, with reference to clauses 3.15.1 <sup>(1)(2)</sup> , 3.15.4 <sup>(1)(2)</sup> and 3.15.5 <sup>(1)(2)</sup> . See section 3 of this Certificate.
Standard:	6.1(b)(c)	Energy demand
Comment:		The products can contribute to satisfying this Standard, with reference to clauses 6.1.1 <sup>(1)</sup> and 6.1.2 <sup>(2)</sup> . See section 6 of this Certificate.
Standard:	6.2	Building insulation envelope
Comment:		The products can contribute to satisfying this Standard, with reference to clauses 6.2.1 <sup>(1)(2)</sup> , 6.2.3 <sup>(1)</sup> , 6.2.4 <sup>(2)</sup> , 6.2.8 <sup>(1)</sup> , 6.2.9 <sup>(2)</sup> and 6.2.12 <sup>(1)</sup> . See section 6 of this Certificate.
Standard:	7.1(a)(b)	Statement of Sustainability
Comment:		The products can contribute to satisfying the relevant requirements of Regulation 9, Standards 1 to 6, and therefore will contribute to a construction meeting a bronze level of sustainability as defined in this Standard. In addition, the products can contribute to a construction meeting a higher level of sustainability as defined in this Standard, with reference to clauses 7.1.4 <sup>(1)</sup> , 7.1.6 <sup>(1)(2)</sup> , 7.1.7 <sup>(1)</sup> , 7.1.9 <sup>(2)</sup> and 7.1.10 <sup>(2)</sup> . See section 6 of this Certificate.
<b>Regulation:</b>	<b>12</b>	<b>Building standards – conversion</b>
Comment:		Comments in relation to the products under Regulation 9, Standards 1 to 6, also apply to this Regulation, with reference to clause 0.12.1 <sup>(1)(2)</sup> and Schedule 6 <sup>(1)(2)</sup> .

(1) Technical Handbook (Domestic).  
(2) Technical Handbook (Non-Domestic).



## The Building Regulations (Northern Ireland) 2012 (as amended)

<b>Regulation:</b>	<b>23(1)(a)(i)</b>	<b>Fitness of materials and workmanship</b>
Comment:	<b>(iii)(b)(i)(ii)</b>	The products are acceptable. See sections 8 and 9 of this Certificate.

<b>Regulation:</b> Comment:	<b>23(2)</b>	<b>Fitness of materials and workmanship</b> The products are unrestricted by this Regulation. See section 2 of this Certificate.
<b>Regulation:</b> Comment:	<b>28(a)</b>	<b>Resistance to moisture and weather</b> The products can contribute to satisfying this Regulation. See section 3 of this Certificate.
<b>Regulation:</b> Comment:	<b>28(b)</b>	<b>Resistance to moisture and weather</b> The products can contribute to satisfying this Regulation. See section 9 of this Certificate.
<b>Regulation:</b> Comment:	<b>29</b>	<b>Condensation</b> The products can contribute to satisfying this Regulation. See section 3 of this Certificate.
<b>Regulation:</b> Comment:	<b>35(4)</b>	<b>Internal fire spread – structure</b> The products can contribute to satisfying this Regulation. See section 2 of this Certificate.
<b>Regulation:</b> Comment:	<b>36(a)</b>	<b>External fire spread</b> The products are unrestricted by this Regulation. See section 2 of this Certificate.
<b>Regulation:</b> <b>Regulation:</b> <b>Regulation:</b> Comment:	<b>39(a)(i)</b> <b>40(2)</b> <b>43B</b>	<b>Conservation measures</b> <b>Target carbon dioxide emission rate</b> <b>Nearly zero-energy requirements for new buildings</b> The products can contribute to satisfying these Regulations. See section 6 of this Certificate.

## Additional Information

### NHBC Standards 2025

In the opinion of the BBA, Isover Cavity Wall Slab (CWS) 36, Isover Cavity Wall Slab (CWS) 34 and Isover Cavity Wall Slab (CWS) 32 for partial fill, if installed, used and maintained in accordance with this Certificate, can satisfy or contribute to satisfying the relevant requirements in relation to *NHBC Standards*, Chapter 6.1 *External masonry walls*.

The opinion of the BBA does not amount to any endorsement or approval by NHBC and does not in any way guarantee that NHBC will approve such product / system as compliant with the NHBC Technical Requirements and Standards.

## Fulfilment of Requirements

The BBA has judged Isover Cavity Wall Slab (CWS) 36, Isover Cavity Wall Slab (CWS) 34 and Isover Cavity Wall Slab (CWS) 32 for partial fill to be satisfactory for use as described in this Certificate. The products have been assessed for use as a partial fill thermal insulation in new external masonry cavity walls with a minimum residual cavity of 50 mm, in domestic and non-domestic buildings without height restrictions. Additional requirements apply for buildings above 25 metres in height. The products are installed during construction.

## ASSESSMENT

### Product description and intended use

The Certificate holder provided the following description for the products. Isover Cavity Wall Slab (CWS) 36, Isover Cavity Wall Slab (CWS) 34 and Isover Cavity Wall Slab (CWS) 32 for partial fill consist of layers of bonded, water-repellent-treated glass mineral wool, formed into slabs using a resin binder.

The products have the nominal characteristics given in Table 1.

*Table 1 Nominal characteristics*

Characteristic (unit)	Value		
	Isover Cavity Wall Slab (CWS) 36	Isover Cavity Wall Slab (CWS) 34	Isover Cavity Wall Slab (CWS) 32
Length (mm)	1200	1200	1200
Width (mm)	455	455	455
Thickness (mm)	50, 65, 75, 85, 100, 125, 150	75, 100, 125, 150	65, 75, 85, 100, 125, 150

#### Ancillary Items

The Certificate holder recommends cavity wall ties to BS EN 845-1 : 2013 as ancillary items for use with the products, but these materials have not been assessed by the BBA and are outside the scope of this Certificate.

#### Applications

The products are intended for use as partial fill cavity wall thermal insulation in external cavity walls with masonry inner and outer leaves (where masonry includes clay and calcium silicate bricks, concrete blocks, and natural and reconstituted stone blocks). Where natural or reconstituted stone is used, it must be dressed so that the cavity formed is uniform and both faces are parallel.

The products may be installed as multi layers where required.

## Product assessment – key factors

The products were assessed for the following key factors, and the outcome of the assessments is shown below. Conclusions relating to the Building Regulations apply to the whole of the UK unless otherwise stated.

### 1 Mechanical resistance and stability

Not applicable.

### 2 Safety in case of fire

Data were assessed for the following characteristic.

#### 2.1 Reaction to fire

2.1.1 The products were tested for reaction to fire and the classifications achieved are given in Table 2.

*Table 2 Reaction to fire classification*

Product assessed	Assessment method	Requirement	Result
Isover Cavity Wall Slab (CWS) 36 <sup>(1)</sup>	BS EN 13501-1 : 2018	Value achieved	A1
Isover Cavity Wall Slab (CWS) 34 <sup>(1)</sup>			
Isover Cavity Wall Slab (CWS) 32 <sup>(1)</sup>			

(1) Warringtonfire, classification report number WF 426589, 17 November 2020, copies available from the Certificate holder on request.

2.1.2 On the basis of data assessed, the products will be unrestricted in terms of building height and proximity to a relevant boundary under the documents supporting the national Building Regulations.

2.1.3 Designers must refer to the relevant national Building Regulations and guidance for detailed conditions of use, particularly in respect of requirements for substrate fire performance, cavity closers and barriers, fire stopping of service penetrations and combustibility limitations for other materials and components used in the overall wall construction.

### 3 Hygiene, health and the environment

Data were assessed for the following characteristics.

#### 3.1 Effectiveness against rising damp

3.1.1 The products were tested for short-term water absorption by partial immersion and the results are given in Table 3.

*Table 3 Short-term water absorption by partial immersion*

Product assessed	Assessment method	Requirement	Result
Isover Cavity Wall Slab (CWS) 36	BS EN 1609 : 2013	$\leq 1.0 \text{ kg}\cdot\text{m}^{-2}$	Pass
Isover Cavity Wall Slab (CWS) 34			
Isover Cavity Wall Slab (CWS) 32			

3.1.2 On the basis of data assessed, the products may be used in situations where they bridge the damp-proof course (DPC) in walls; dampness from the ground will not pass through to the inner masonry leaf provided the wall is detailed in accordance with the requirements and provisions of the national Building Regulations.

#### 3.2 Water vapour permeability

3.2.1 The products were assessed for water vapour resistivity and the results are given in Table 4.

*Table 4 Water vapour resistivity*

Product assessed	Assessment method	Requirement	Result
Isover Cavity Wall Slab (CWS) 36	BS EN ISO 10456 : 2007	Declared value	$5 \text{ MN}\cdot\text{s}\cdot\text{g}^{-1}\cdot\text{m}^{-1}$
Isover Cavity Wall Slab (CWS) 34			
Isover Cavity Wall Slab (CWS) 32			

3.2.2 For the purposes of assessing the risk of condensation, the water vapour resistivity value may be taken as stated in Table 4.

### 4 Safety and accessibility in use

Not applicable.

### 5 Protection against noise

Not applicable.

### 6 Energy economy and heat retention

Data were assessed for the following characteristics.

#### 6.1 Thermal conductivity

The products were tested for thermal conductivity and the results are given in Table 5.

*Table 5 Thermal conductivity*

Product assessed	Assessment method	Requirement	Result
Isover Cavity Wall Slab (CWS) 36	BS EN 13162 : 2012	Declared value ( $\lambda_D$ )	$0.036 \text{ W}\cdot\text{m}^{-1}\cdot\text{K}^{-1}$
Isover Cavity Wall Slab (CWS) 34			$0.034 \text{ W}\cdot\text{m}^{-1}\cdot\text{K}^{-1}$
Isover Cavity Wall Slab (CWS) 32			$0.032 \text{ W}\cdot\text{m}^{-1}\cdot\text{K}^{-1}$

## 6.2 Thermal performance

6.2.1 The U value of a completed wall construction will depend on the insulation conductivity, thickness, the number and type of fixings, the wall structure, and its internal finish. Example U values are given in Table 6.

**Table 6 Example U Values<sup>(1)</sup>**

Target U value (W·m <sup>-1</sup> ·K <sup>-1</sup> )	Insulation thickness (mm) <sup>(2)</sup>					
	13 mm dense plaster 100 mm dense block <sup>(3)</sup>			Plasterboard on dabs 100 mm AAC block <sup>(4)</sup>		
	Isover Cavity Wall Slab (CWS) 36	Isover Cavity Wall Slab (CWS) 34	Isover Cavity Wall Slab (CWS) 32	Isover Cavity Wall Slab (CWS) 36	Isover Cavity Wall Slab (CWS) 34	Isover Cavity Wall Slab (CWS) 32
0.13	250 <sup>(5)</sup>	250 <sup>(5)</sup>	225 <sup>(5)</sup>	225 <sup>(5)</sup>	225 <sup>(5)</sup>	200 <sup>(5)</sup>
0.15	225 <sup>(5)</sup>	200 <sup>(5)</sup>	200 <sup>(5)</sup>	185 <sup>(5)</sup>	175 <sup>(5)</sup>	170 <sup>(5)</sup>
0.17	185 <sup>(5)</sup>	175 <sup>(5)</sup>	170 <sup>(5)</sup>	160 <sup>(5)</sup>	150	150
0.18	175 <sup>(5)</sup>	175 <sup>(5)</sup>	160 <sup>(5)</sup>	150	150	150
0.21	150	150	150	125	125	125
0.26	125	125	125	100	100	85
0.28	125	100	100	85	75	75
0.30	100	100	100	75	75	65
0.35	85	100	75	65	75	65

(1) The U value calculations are based on the following:

- wall ties: stainless steel ( $\lambda = 17 \text{ W}\cdot\text{m}^{-1}\cdot\text{K}^{-1}$ ), 2.5 per m<sup>2</sup>, 12.5 mm<sup>2</sup> cross-section.
- 102.5 mm brick ( $\lambda = 0.77 \text{ W}\cdot\text{m}^{-1}\cdot\text{K}^{-1}$ ) bridged by mortar (17.3%,  $\lambda = 0.94 \text{ W}\cdot\text{m}^{-1}\cdot\text{K}^{-1}$ )
- 50mm clear cavity ( $R = 0.180 \text{ m}^2\cdot\text{K}\cdot\text{W}^{-1}$ )

(2) Based upon incremental insulation thickness range in Table 1.

(3) 100 mm dense block ( $\lambda = 1.13 \text{ W}\cdot\text{m}^{-1}\cdot\text{K}^{-1}$ ) bridged by mortar (6.6%,  $\lambda = 0.88 \text{ W}\cdot\text{m}^{-1}\cdot\text{K}^{-1}$ ) and 13 mm dense plaster ( $\lambda = 0.57 \text{ W}\cdot\text{m}^{-1}\cdot\text{K}^{-1}$ ).

(4) 100 mm AAC block ( $\lambda = 0.12 \text{ W}\cdot\text{m}^{-1}\cdot\text{K}^{-1}$ ) bridged by mortar (6.6%,  $\lambda = 0.88 \text{ W}\cdot\text{m}^{-1}\cdot\text{K}^{-1}$ ) and 12.5 mm plasterboard ( $\lambda = 0.25 \text{ W}\cdot\text{m}^{-1}\cdot\text{K}^{-1}$ ) on 15 mm air cavity ( $R = 0.17 \text{ m}^2\cdot\text{K}\cdot\text{W}^{-1}$ ) bridged by adhesive dabs (20%,  $\lambda = 0.43 \text{ W}\cdot\text{m}^{-1}\cdot\text{K}^{-1}$ ).

(5) Thickness achieved with two layers of insulation.

6.2.2 On the basis of data assessed, the products can contribute towards a construction satisfying the national Building Regulations in respect of energy economy and heat retention.

## 7 Sustainable use of natural resources

Not applicable.

## 8 Durability

8.1 The potential mechanisms for degradation and the known performance characteristics of the materials in the products were assessed.

8.2 Specific test data were assessed as given in Table 7.

**Table 7 Dimensional stability**

Product assessed	Assessment method	Requirement	Result
Isover Cavity Wall Slab (CWS) 36	BS EN 1604 : 2013 (70°C and 90% RH for 48 hours)	Length, width and reduction in thickness $\leq$ 1% change	Pass
Isover Cavity Wall Slab (CWS) 34			
Isover Cavity Wall Slab (CWS) 32			

### 8.3 Service life

Under normal service conditions, the products will have a life equivalent to the structure in which they are incorporated, provided they are designed, installed, and maintained in accordance with this Certificate and the Certificate holder's instructions.

Information provided by the Certificate holder was assessed for the following factors:

### 9 Design, installation, workmanship and maintenance

#### 9.1 Design

9.1.1 The design process was assessed, and the following requirements apply in order to satisfy the performance assessed in this Certificate.

9.1.2 Buildings subject to the national Building Regulations must be constructed in accordance with the relevant recommendations of:

- BS 5250 : 2021
- BS 8000-3 : 2020
- BS EN 845-1 : 2013
- BS EN 1996-1-1 : 2005 and its UK National Annex
- BS EN 1996-1-2 : 2005 and its UK National Annex
- BS EN 1996-2 : 2006 and its UK National Annex
- BS EN 1996-3 : 2006 and its UK National Annex.

9.1.3 As with other forms of cavity wall insulation, where buildings need to comply with *NHBC Standards 2025*, specifiers must observe the requirements of that document.

9.1.4 Cavity wall ties with insulation-retaining fixings and, if required, any additional ties to BS EN 845-1 : 2013 must be used for structural stability in accordance with the principles of BS EN 1996-1-1 : 2005, BS EN 1996-2 : 2006 and BS EN 1996-3 : 2006, and their UK National Annexes.

9.1.5 Care must be taken in the overall design and construction of walls incorporating the products to ensure the provision of appropriate:

- cavity trays and DPCs
- cavity barriers and fire stopping
- resistance to the ingress of precipitation, moisture and dangerous gases from the ground
- resistance to sound transmission when flanking separating walls and floors.

9.1.6 Provided that external masonry cavity walls are designed and constructed to incorporate the precautions in this Certificate to prevent moisture penetration, the product will resist transfer of precipitation to the inner leaf.

9.1.7 This Certificate covers the use of the product in any exposure zone. However, use of the product does not preclude the need to apply any external render coat or other suitable finish in severe exposure zones where such application would be normal practice.

9.1.8 Window and door opening reveals must be constructed incorporating a cavity barrier/closer/DPC, as required.

9.1.9 The detailed provisions given in the documents supporting the national Building Regulations for when the products are installed in close proximity to certain flue pipes and/or heat-producing appliances must be followed.

9.1.10 Calculations of the thermal transmittance (U value) of a wall must be carried out in accordance with BS EN ISO 6946 : 2017 and BRE Report BR 443 : 2019.

9.1.11 Care must be taken in the overall design and construction of junctions with other elements and openings to minimise thermal bridges and air infiltration. Detailed guidance can be found in the documents supporting the national Building Regulations.

### *Interstitial condensation*

9.1.12 Walls will adequately limit the risk of interstitial condensation when they are designed and constructed in accordance with BS 5250 : 2021.

9.1.13 If the products are to be used in the external walls of rooms expected to have high humidity, care must be taken to provide adequate permanent ventilation to avoid possible problems from the formation of interstitial condensation.

### *Surface condensation*

9.1.14 In England and Wales, walls will adequately limit the risk of surface condensation when the thermal transmittance (U value) does not exceed  $0.7 \text{ W}\cdot\text{m}^{-2}\cdot\text{K}^{-1}$  at any point, and the junctions with other elements are designed in accordance with the guidance referred to in section 9.1.11 of this Certificate.

9.1.15 For buildings in Scotland, wall constructions will be acceptable when the thermal transmittance (U value) does not exceed  $1.2 \text{ W}\cdot\text{m}^{-2}\cdot\text{K}^{-1}$  at any point, and the junctions with other elements are designed in accordance with the guidance referred to in BS 5250 : 2021. Further guidance may be obtained from BRE Report BR 262 : 2002 and section 9.1.11 of this Certificate.

### *Buildings up to and including 25 metres high*

9.1.16 The residual cavity width to be maintained during construction is 50 mm. This may reduce to 25 mm in isolated areas due to individual construction features (a minimum of 50 mm residual cavity width is required by the NHBC). This may be achieved by designing a cavity width which considers the dimensional tolerances of the components which make up the wall (by reference to the British Standards relating to the bricks and blocks), or by using the data from the respective manufacturers. Allowances may need to be made for the quality of building operatives and the degree of site supervision or control available. The limitations in respect of exposure of the proposed building as set out in Table 8 must also be observed.

*Table 8 Maximum allowable exposure index  $E^{(1)}$*

Construction	Maximum allowable exposure index $E^{(1)}$
All external masonry walls protected by rendering (to BS EN 13914-1 : 2016), tile hanging, slate hanging, or timber, plastic or metal weatherboarding or cladding	No restriction
One or more external masonry walls constructed from facing clay brickwork or natural stone, the porosity of which exceeds 20% by volume. Mortar joints must be flush, pointed, or weatherstruck	100
One or more external masonry wall constructed from calcium silicate bricks, concrete blocks, reconstituted stone, or natural stone, the porosity of which is less than 20% by volume, or any material with raked mortar joints	88

(1) To BS 5618 : 1985.

9.1.17 From ground level, the maximum height of continuous cavity walls must not exceed 12 metres; above 12 metres, the maximum height of continuous cavity walls must not exceed 7 metres. In both cases, breaks must be in the form of continuous horizontal cavity trays and weepholes discharging to the outside.

### *Buildings over 25 metres in height*

9.1.18 The width of the residual clear cavity to be achieved must be in excess of 50 mm, and the following additional requirements apply in addition to those stated in sections 9.1.16 and 9.1.17:

- the specifier must take extra care when detailing to ensure that the introduction of the insulation does not affect the weather resistance of the wall. Above average site supervision is recommended during installation of the products
- where, for structural reasons, the cavity width is reduced, eg by the intrusion of ring beams, a minimum residual cavity width of 25 mm must be maintained and extra care must be taken with fixings and weatherproofing, eg by the inclusion of cavity trays with weepholes.

## 9.2 Installation

9.2.1 Installation instructions provided by the Certificate holder were assessed and judged to be appropriate and adequate.

9.2.2 Installation must be carried out in accordance with this Certificate and the Certificate holder's instructions. A summary of instructions and guidance are provided in Annex A of this Certificate.

9.2.3 The internal leaf must be constructed ahead of the external leaf so that any mortar protruding into the cavity space from the back of the internal leaf can be cleaned off before installing the products. Slabs must not be pushed into a completed cavity.

9.2.4 Vertical joints in the slabs must be staggered and all joints tightly butted. Where protrusions occur in the cavity, the slabs must be carefully cut to fit.

9.2.5 If installation of the slabs is terminated below the highest level of the wall, the top edge of the insulation must be protected by a cavity tray and alternate perpend of the masonry outer leaf joints raked out, to provide adequate drainage of water from the tray.

9.2.6 In all situations, it is particularly important to ensure during installation that:

- installation is carried out to the highest level on each wall, or the top edge of the insulation is protected by a cavity tray
- cavity trays are used with appropriate stop ends and weepholes at lintel level
- cavity battens and/or boards are used during construction to prevent bridging by mortar droppings
- wall ties are installed correctly and are thoroughly clean
- excess mortar is cleaned from the cavity face of the leading leaf and any debris removed from the cavity
- mortar droppings are cleaned from the exposed edges of installed slabs
- insulation slabs are properly installed, and butt jointed
- the DPC at ground level does not project into the cavity as it can form a trap for mortar bridging
- raked or recessed mortar joints are avoided in very severe exposure areas.

9.2.7 Partially completed walls must be protected from inclement weather (wind, rain and snow) and covered at the end of a day's work.

## 9.3 Workmanship

Practicability of installation was assessed by the BBA, on the basis of the Certificate holder's information. To achieve the performance described in this Certificate, installation of the products must be carried out by a competent general builder, or a contractor, experienced with these types of products.

## 9.4 Maintenance and repair

As the products are contained within the wall cavity and have suitable durability, maintenance is not required.

# 10 **Manufacture**

10.1 The production processes for the products have been assessed, and provide assurance that the quality controls are satisfactory according to the following factors:

10.1.1 The manufacturer has provided documented information on the materials, processes, testing and control factors.

10.1.2 The quality control operated over batches of incoming materials has been assessed and deemed appropriate and adequate.

10.1.3 The quality control procedures and product testing to be undertaken have been assessed and deemed appropriate and adequate.

10.1.4 The process for management of non-conformities has been assessed and deemed appropriate and adequate.

10.1.5 An audit of each production location was undertaken, and it was confirmed that the production process was in accordance with the documented process, and that equipment has been properly tested and calibrated.

† 10.2 The BBA has undertaken to review the above measures on a regular basis through a surveillance process, to verify that the specifications and quality control operated by the manufacturer are being maintained.

## **11 Delivery and site handling**

11.1 The Certificate holder stated that the products are delivered to site in polythene-wrapped packs bearing a label including the Certificate holder's name, slab dimensions and the BBA logo incorporating the number of this Certificate.

11.2 Delivery and site handling must be performed in accordance with the Certificate holder's instructions and this Certificate, including the following:

11.2.1 The products must be protected from prolonged exposure to sunlight, and stored dry, flat and raised above ground level (to avoid contact with ground moisture). Where possible, packs should be stored inside. If stored outside, they must be under cover or protected with opaque polythene sheeting.

11.2.2 It is recommended that dust masks, gloves and long-sleeved clothing are worn during cutting and handling.

11.2.3 Damaged, contaminated or wet products must not be used.

Supporting information in this Annex is relevant to the products but has not formed part of the material assessed for the Certificate.

### Construction (Design and Management) Regulations 2015

### Construction (Design and Management) Regulations (Northern Ireland) 2016

Information in this Certificate may assist the client, designer (including Principal Designer) and contractor (including Principal Contractor) to address their obligations under these Regulations.

### UKCA marking

The Certificate holder has taken the responsibility of UKCA marking the products in accordance with Designated Standard EN 13162 : 2012.

### CE marking

The Certificate holder has taken the responsibility of CE marking the products, in accordance with harmonised European Standard EN 13162 : 2012.

### Management Systems Certification for production

The management system of the manufacturer has been assessed and registered as meeting the requirements of ISO 9001 : 2015 and ISO 14001 : 2015 by BSI (Certificates FM 674646 and EMS 674645 respectively).

### Additional information on installation

Installation must be in accordance with the Certificate holder's instructions and this Certificate. A summary of precautions and the procedure is provided below:

#### General

A.1 The Certificate holder will provide on-site demonstrations on request, to ensure correct installation from the outset.

A.2 Adequate supervision of the installation should be maintained, and the Certificate holder must have right of access to site to ensure correct installation.

#### Procedure

A.3 Walls re constructed in the conventional manner with the first row of wall ties, at approximately 600 mm horizontal spacing, where the insulation is to begin. The wall ties should not be placed directly on the DPC. The first run of slabs should commence at least 150 mm below the DPC level to provide some edge insulation for the floor (see Figure 1).

**Figure 1 Building-in the first row of slabs**

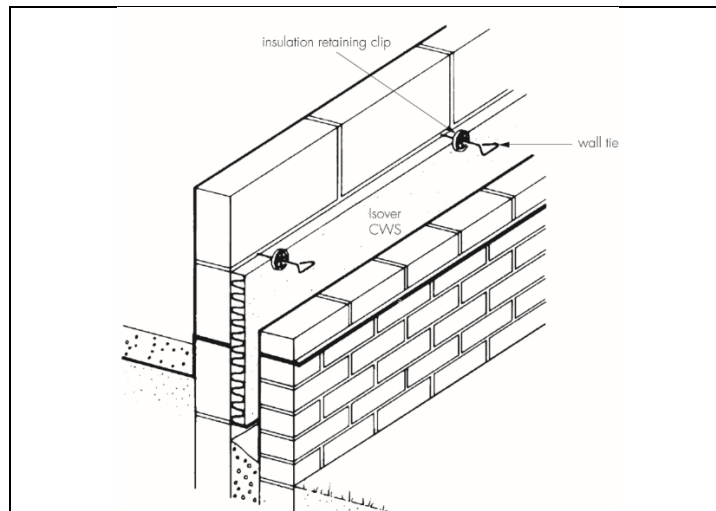

A.4 The external leaf is then built up to a course above the next row of wall ties, which are placed at a vertical spacing of 450 mm, and not more than 900 mm horizontally, to ensure that each slab is secured at a minimum of three points in accordance with BS EN 1996-1-2 : 2005.

A.5 Slabs are compressed slightly and placed between the upper and lower wall ties to form a closely butt-jointed run (see Figure 1).

A.6 It is essential that all wall ties slope downwards towards the external leaf, with the drip positioned in the centre of the slabs pointing downwards to shed water away from the internal leaf (see Figure 2). It is also important that the first row of slabs is not in contact with the ground.

**Figure 2 Partial fill wall tie detail**

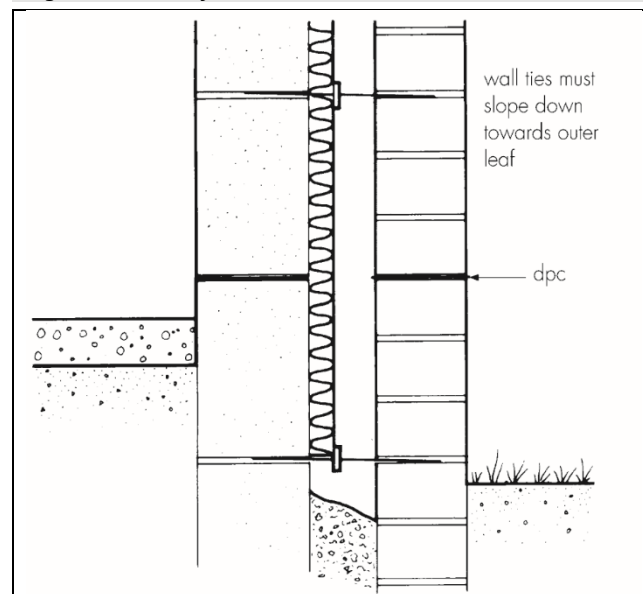

A.7 The internal leaf is built up to the same level as the insulation slabs, with its inner face in contact with the slabs (see Figure 2).

A.8 Successive sections of wall, incorporating wall ties, are constructed and the slabs installed as work proceeds up to the required height.

A.9 Slabs should be installed to the highest level of each wall.

## Mortar droppings

A.10 After each section of the wall leaf is built, excess mortar must be removed from the cavity and mortar droppings cleaned from exposed edges of the installed slab before installation of the next section of slabs. Use of a cavity board or a cavity batten is recommended to protect slab edges and make cleaning easier (see Figures 3 and 4).

Figure 3 Removal of excess mortar

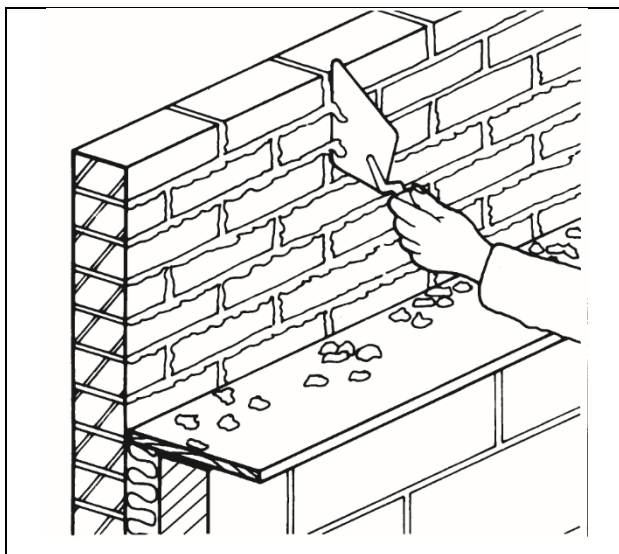
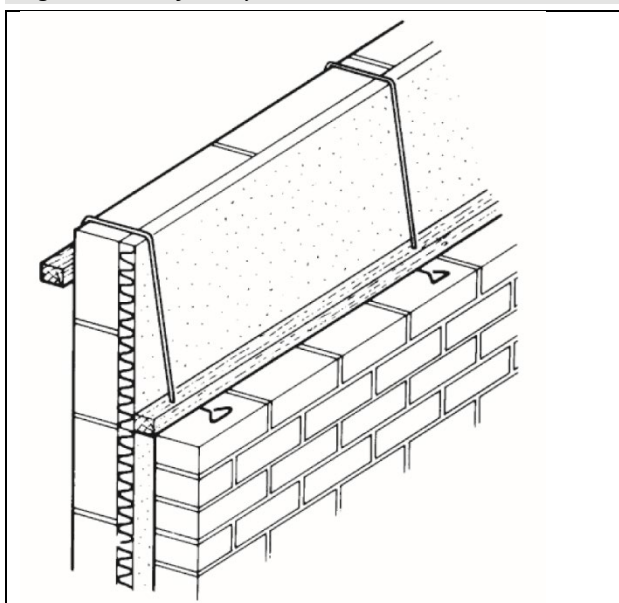

Figure 4 Use of cavity battens



## Corners

A.11 Slabs should be closely butted at corners (see Figure 5) to avoid cold bridges (uncut slabs should be used for this purpose).

*Figure 5 Slabs at corner detail*

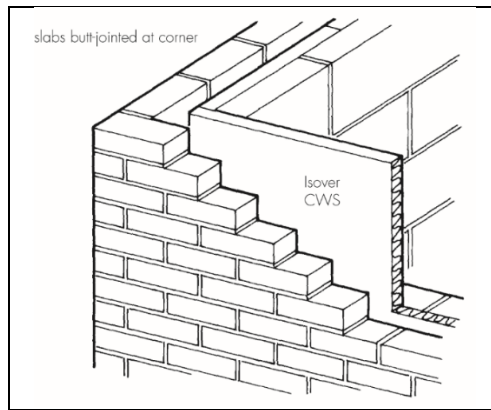

### Wall openings

A.12 Where openings such as doors and windows are in close proximity, it is recommended that a continuous lintel or cavity tray is used. Individual lintels or cavity trays must have stopends and be adequately drained. Slabs should be cut to butt tightly against the cavity barrier/closer/DPC.

### Cut pieces

A.13 Slabs can be cut, using a sharp knife or fine-toothed saw, to fit around windows, doors, apertures and air bricks.

A.14 It is essential that cut pieces of slab completely fill the spaces for which they are intended, and no gaps are left in the insulation (see Figure 6).

*Figure 6 Cut pieces are used to fill gaps*

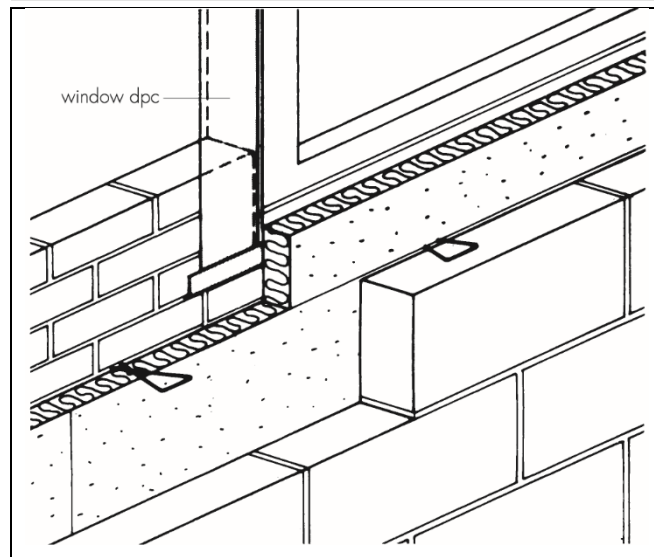

A.15 Small pieces of slab must be fitted, with the fibre layer parallel to the plane of the wall, so their faces (not their edges) are against the face of the wall.

### Multi layers (when required)

A.16 When installing two or three layers of slabs, a similar procedure must be followed as for the single layer. The first layer is fitted against the outer masonry leaf followed by the second and third layer. The vertical joints in the second or third layer must not be coincident with those in the previous layer.

A.17 For cavities exceeding 150 mm, the Certificate holder's instructions must be followed regarding the type of ties to be used, and the installation should be carried out in accordance with BS EN 1996-1-2 : 2005, BS EN 1996-2 : 2006 and BS EN 1996-3 : 2006.

## **Protection**

A.18 Exposed areas of slabs should always be covered at the end of the day's work or in driving rain.

A.19 All building work involving the products, particularly interrupted work, must conform to BS EN 1996-2 : 2006, Clauses 3.2 *Acceptance, handling and storage of materials* and 3.6 *Curing and protective procedures during execution*.

## Bibliography

- BRE Report BR 262 : 2002 *Thermal insulation : avoiding risks*
- BRE Report BR 443 : 2019 *Conventions for U-value calculations*
- BS 5250 : 2021 *Management of moisture in buildings — Code of practice*
- BS 5618 : 1985 *Code for practice for thermal insulation of cavity walls (with masonry or concrete inner and outer leaves) by filling with urea-formaldehyde (UF) foam systems (incorporating amendment Nos. 1 and 2)*
- BS 8000-3 : 2020 *Workmanship on building sites — Code of practice for masonry*
- BS EN 845-1 : 2013 + A1 : 2016 *Specification for ancillary components for masonry — Wall ties, tension straps, hangers and brackets*
- BS EN 1604 : 2013 *Thermal insulating products for building applications — Determination of dimensional stability under specified temperature and humidity conditions*
- BS EN 1609 : 2013 *Thermal insulating products for building applications — Determination of short term water absorption by partial immersion*
- BS EN 1996-1-1 : 2005 + A1 : 2012 *Eurocode 6 : Design of masonry structures — General rules for reinforced and unreinforced masonry structures*
- NA to BS EN 1996-1-1 : 2005 + A1 : 2012 *UK National Annex to Eurocode 6 : Design of masonry structures — General rules for reinforced and unreinforced masonry structures*
- BS EN 1996-1-2 : 2005 *Eurocode 6 : Design of masonry structures — General rules — Structural fire design*
- NA to BS EN 1996-1-2 : 2005 *UK National Annex to Eurocode 6 : Design of masonry structures — General rules — Structural fire design*
- BS EN 1996-2 : 2006 *Eurocode 6 : Design of masonry structures — Design considerations, selection of materials and execution of masonry*
- NA to BS EN 1996-2 : 2006 *UK National Annex to Eurocode 6 : Design of masonry structures — Design considerations, selection of materials and execution of masonry*
- BS EN 1996-3 : 2006 *Eurocode 6 : Design of masonry structures — Simplified calculation methods for unreinforced masonry structures*
- NA + A1 : 2014 to BS EN 1996-3 : 2006 *UK National Annex to Eurocode 6 : Design of masonry structures — Simplified calculation methods for unreinforced masonry structures*
- BS EN 13162 : 2012 + A1 : 2015 *Thermal insulation products for buildings — Factory made mineral wool (MW) products — Specification*
- BS EN 13501-1 : 2018 *Fire classification of construction products and building elements — Classification using test data from reaction to fire tests*
- BS EN 13914-1 : 2016 *Design, preparation and application of external rendering and internal plastering - External rendering*
- BS EN ISO 6946 : 2017 *Building components and building elements — Thermal resistance and thermal transmittance — Calculation method*
- BS EN ISO 10456 : 2007 *Building materials and products — Hygrothermal properties — Tabulated design values and procedures for determining declared and design thermal values*
- ISO 9001 : 2015 *Quality management products — Requirements*
- ISO 14001 : 2015 *Environmental management systems — Requirements with guidance for use*

### Conditions

1 This Certificate:

- relates only to the product that is named and described on the front page
- is issued only to the company, firm, organisation or person named on the front page – no other company, firm, organisation or person may hold or claim that this Certificate has been issued to them
- has to be read, considered and used as a whole document – it may be misleading and will be incomplete to be selective
- is copyright of the BBA
- and any matter arising out of or in connection with it or its subject matter (including non-contractual disputes or claims) is governed by and construed in accordance with the law of England and Wales.
- the courts of England and Wales shall have exclusive jurisdiction to settle any matter arising out of or in connection with this Certificate or its subject matter (including non-contractual disputes or claims).

2 Publications, documents, specifications, legislation, regulations, standards and the like referenced in this Certificate are those that were current and/or deemed relevant by the BBA at the date of issue or reissue of this Certificate.

3 This Certificate will be displayed on the BBA website, and the Certificate Holder is entitled to use the Certificate and Certificate logo, provided that the product and its manufacture and/or fabrication, including all related and relevant parts and processes thereof:

- are maintained at or above the levels which have been assessed and found to be satisfactory by the BBA
- continue to be checked as and when deemed appropriate by the BBA under arrangements that it will determine
- are reviewed by the BBA as and when it considers appropriate.

4 The BBA has used due skill, care and diligence in preparing this Certificate, but no warranty is provided.

5 In issuing this Certificate the BBA is not responsible and is excluded from any liability to any company, firm, organisation or person, for any matters arising directly or indirectly from:

- the presence or absence of any patent, intellectual property or similar rights subsisting in the product or any other product
- the right of the Certificate holder to manufacture, supply, install, maintain or market the product
- actual installations of the product, including their nature, design, methods, performance, workmanship and maintenance
- any works and constructions in which the product is installed, including their nature, design, methods, performance, workmanship and maintenance
- any loss or damage, including personal injury, howsoever caused by the product, including its manufacture, supply, installation, use, maintenance and removal
- any claims by the manufacturer relating to UKCA marking and CE marking.

6 Any information relating to the manufacture, supply, installation, use, maintenance and removal of this product which is contained or referred to in this Certificate is the minimum required to be met when the product is manufactured, supplied, installed, used, maintained and removed. It does not purport in any way to restate the requirements of the Health and Safety at Work etc. Act 1974, or of any other statutory, common law or other duty which may exist at the date of issue or reissue of this Certificate; nor is conformity with such information to be taken as satisfying the requirements of the 1974 Act or of any statutory, common law or other duty of care.